

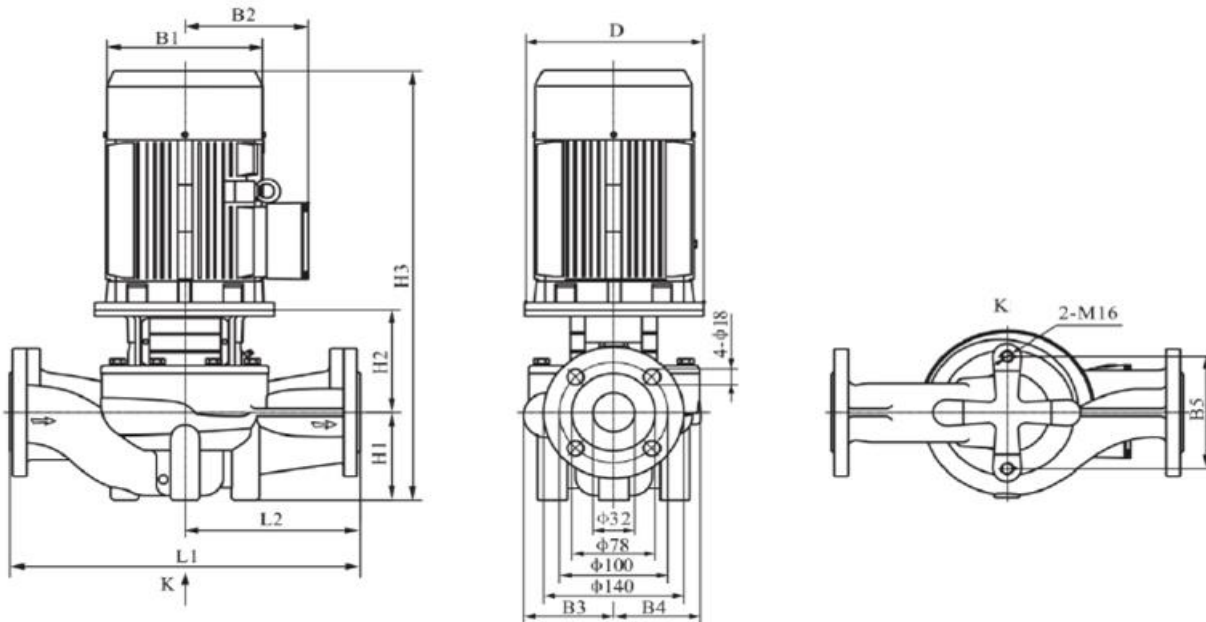

Shoufei Pump

Model	electric motor(KW)	Q(m ³ /h)	2	4	6	8	10	12.5	14	16
TD32-18/2	1.1	H(m)	19.4	19.1	18.7	18.0	16.7	14.3	/	/
TD32-21/2	1.5		24.5	24.2	23.9	23.3	22.5	21.0	19.4	15.9
TD32-25/2	2.2		28.3	25.2	28.0	27.5	26.7	25.0	23.6	20.7
TD32-32/2	3		34.3	34.2	33.9	33.6	33.1	32.0	30.8	28.2
TD32-38/2	4		39.8	39.8	39.7	39.4	39.0	38.0	37.0	35.2
TD32-50/2	5.5		51.7	51.6	51.4	51.1	50.7	50.0	49.3	48.0



Model	Dimension(mm)											Weight (kg)
	D	B1	B2	B3	B4	B5	H1	H2	H3	L1	L2	
TD32-18/2	120	170	142	125	117	144	100	189	540	340	170	36
TD32-21/2	140	190	155	125	117	144	100	199	592	340	170	40
TD32-25/2	140	190	155	125	117	144	100	199	592	340	170	42
TD32-32/2	160	197	165	125	117	144	100	205	619	340	170	48
TD32-38/2	160	230	188	144	144	144	100	207	642	440	220	64
TD32-50/2	200	260	208	144	144	144	100	227	737	440	220	85

Contact: sales@zj-shoufei.com whatsapp/wechat +8613665742262



Shoufei Pump

Model	electric motor(KW)	Q(m ³ /h)	4	8	12.5	16	20	25	28	32
TD40-16/2	1.1	H(m)	17.8	17.3	16.0	12.5	/	/	/	/
TD40-20/2	1.5		21.5	21.1	20.0	17.2	/	/	/	/
TD40-18/2	2.2		19.9	19.8	19.5	19.0	18.0	15.8	/	/
TD40-25/2	3		27.7	27.5	27.1	26.4	25.0	22.5	/	/
TD40-30/2	4		33.8	33.6	33.1	32.6	31.7	30.0	28.6	26.1
TD40-36/2	5.5		39.0	38.8	38.5	38.1	37.3	36.0	35.0	32.6
TD40-48/2	7.5		49.8	49.7	49.5	49.4	49.0	48.0	46.6	44.2

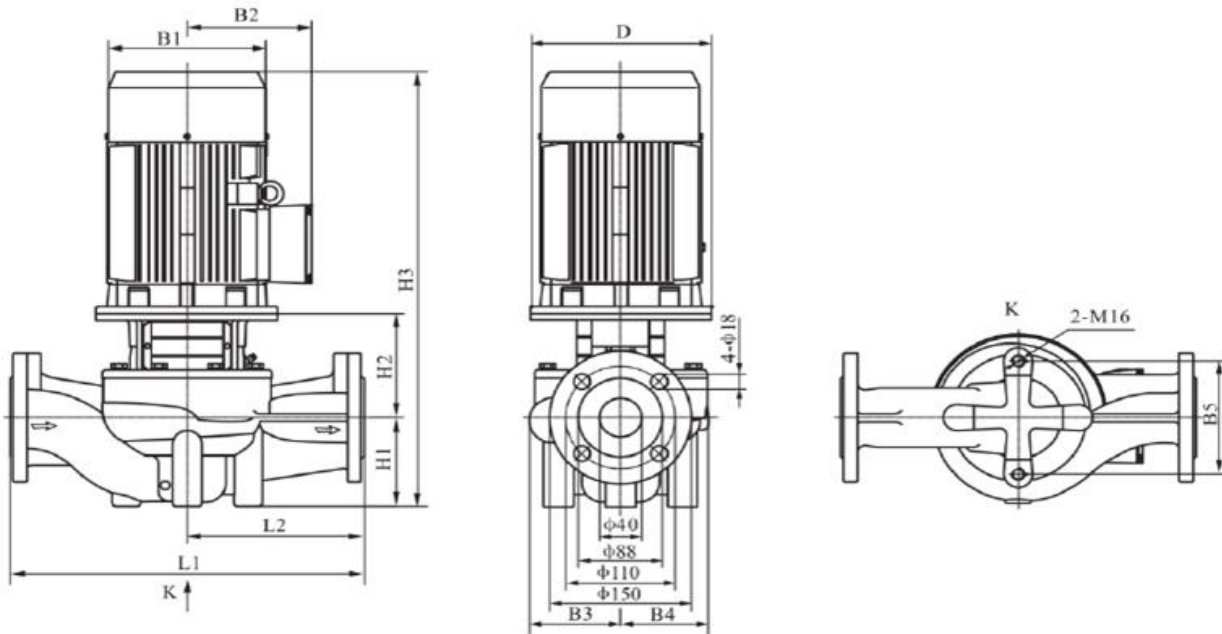

Model	Dimension(mm)											Weight (kg)
	D	B1	B2	B3	B4	B5	H1	H2	H3	L1	L2	
TD40-16/2	120	170	142	97	96	120	68	178	497	320	160	31
TD40-20/2	140	190	155	97	96	120	68	188	549	320	160	36
TD40-18/2	140	190	155	110	95	144	100	195	588	340	170	40
TD40-25/2	160	197	165	127	115	144	100	207	621	340	170	52
TD40-30/2	160	230	188	127	115	144	100	207	642	340	170	62
TD40-36/2	200	260	208	138	125	144	110	227	747	440	220	86
TD40-48/2	200	260	208	138	125	144	110	227	747	440	220	95



Shoufei Pump

Model	electric motor(KW)	Q(m³/h)	2.5	5	7.5	10	12.5	15	17.5	20
TD50-32/2	3	H(m)	35.0	34.6	34.0	33.2	32.0	30.5	27.9	23.3
TD50-38/2	4		40.8	40.6	40.2	39.2	38.0	36.2	33.9	30.4
TD50-48/2	5.5		50.5	50.0	49.7	49.0	48.0	46.5	44.2	40.7

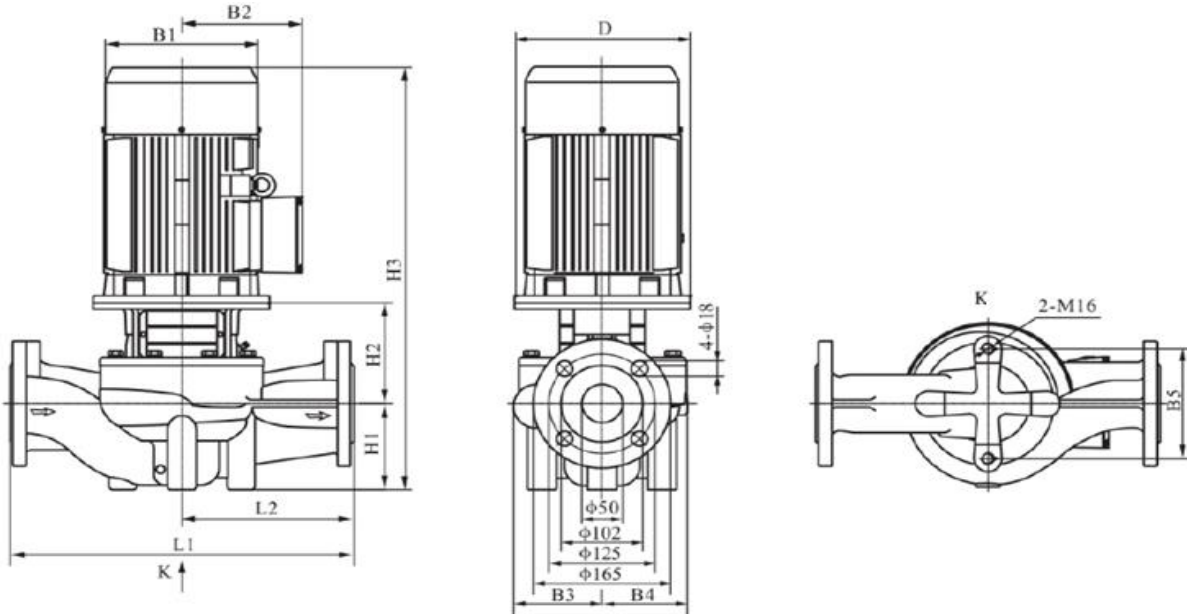

Model	Dimension(mm)											Weight (kg)
	D	B1	B2	B3	B4	B5	H1	H2	H3	L1	L2	
TD50-32/2	160	197	165	128	128	144	105	181	600	400	200	58
TD50-38/2	160	230	188	128	128	144	105	181	621	400	200	68
TD50-48/2	200	260	208	128	128	144	105	201	716	400	200	85



Shoufei Pump

Model	electric motor(KW)	Q(m³/h)	5	10	16	20	25	30	35	40	45	50	60
TD50-12/2	1.1	H(m)	15.2	14.2	12.0	10.0							
TD50-15/2	1.5		18.9	18.0	16.5	15.0	12.6						
TD50-18/2	2.2		22.8	22.3	21.0	19.8	18.0	15.0					
TD50-24/2	3		26.2	26.0	25.5	25.0	24.0	22.3					
TD50-28/2	4		31.5	31.3	31.0	30.5	29.5	28.0	25.5				
TD50-35/2	5.5		36.9	36.7	36.5	36.2	35.8	35.0	33.7	31.5			
TD50-40/2	7.5		42.3	42.2	41.9	41.7	41.3	40.8	40.0	38.3	35.0		
TD50-50/2	11		53.5	53.4	53.1	52.9	52.5	51.9	51.1	50.0	48.4	45.8	
TD50-60/2	15		65.7	65.8	65.7	49.0	48.0	46.5	44.2	40.7	40.7	40.7	40.7
TD50-70/2	18.5		73.7	73.6	73.4	73.3	73.1	72.9	72.5	72.0	71.2	70.0	65.4
TD50-81/2	22		85.5	85.3	85.0	84.8	84.5	84.0	83.5	82.8	82.1	81.0	77.1

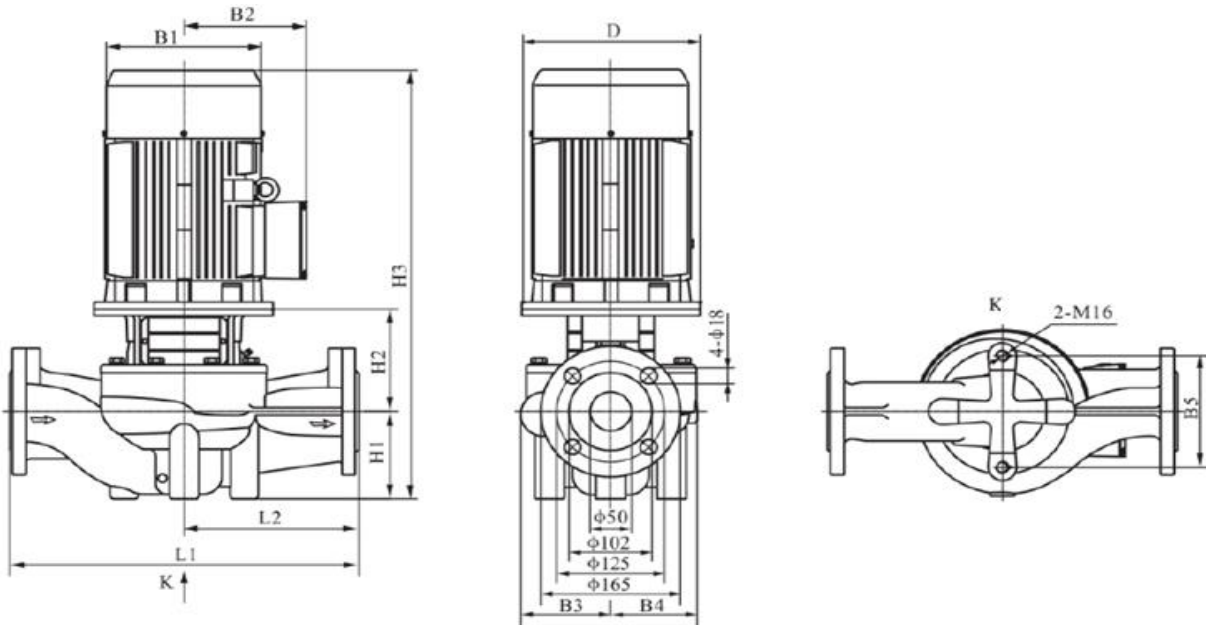

Model	Dimension(mm)											Weight (kg)
	D	B1	B2	B3	B4	B5	H1	H2	H3	L1	L2	
TD50-12/2	120	170	142	117	115	144	105	174	530	340	170	36
TD50-15/2	140	190	155	117	115	144	105	174	572	340	170	42
TD50-18/2	140	190	155	117	115	144	105	174	572	340	170	44
TD50-24/2	160	197	165	117	115	144	105	184	603	340	170	50
TD50-28/2	160	230	188	129	115	144	115	198	648	340	170	64
TD50-35/2	200	260	208	129	115	144	115	218	742	340	170	83
TD50-40/2	200	260	208	171	158	144	115	215	740	440	220	98
TD50-50/2	350	330	255	171	158	144	115	245	902	440	220	172
TD50-60/2	350	330	255	171	158	144	115	245	935	440	220	182
TD50-70/2	350	330	255	171	158	144	115	245	935	440	220	196
TD50-81/2	350	330	280	171	158	144	115	245	965	440	220	238



Shoufei Pump

Model	electric motor(KW)	Q(m ³ /h)	5	10	15.0	20	25.0	30	35.0
TD65-36/2	5.5	H(m)	39.2	39.1	38.9	38.2	36.0	31.8	24.8
TD65-48/2	7.5		50.4	50.3	50.0	49.3	48.0	45.9	42.5

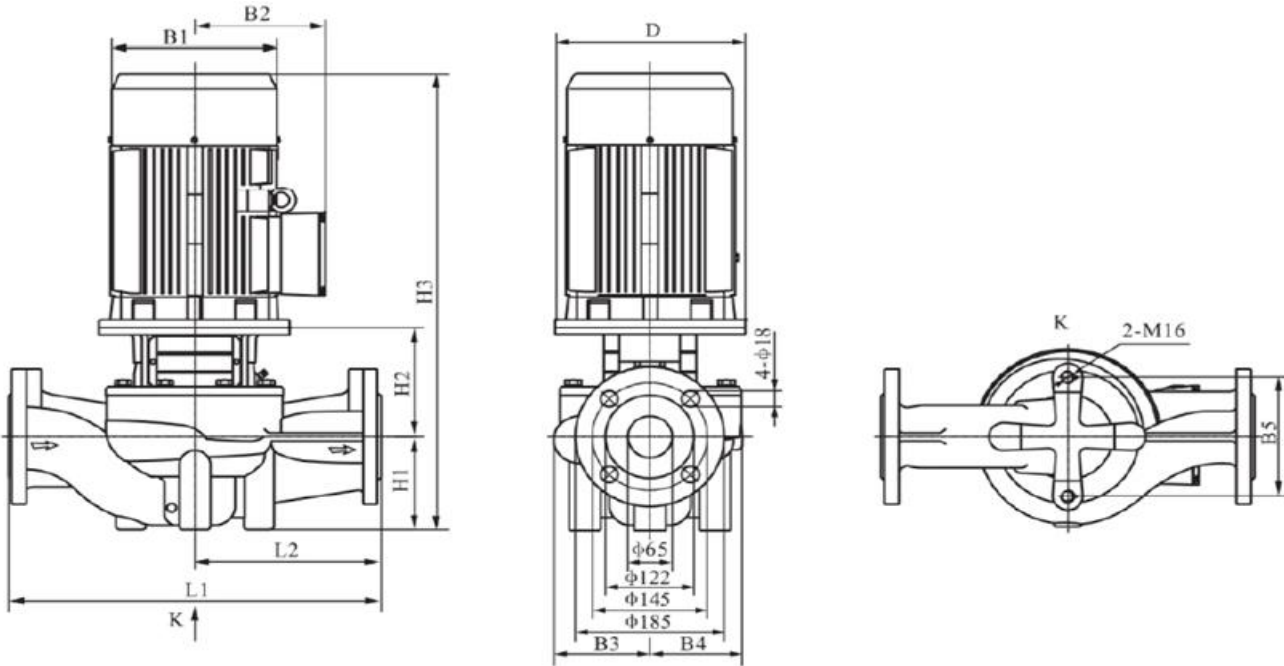

Model	Dimension(mm)											Weight (kg)
	D	B1	B2	B3	B4	B5	H1	H2	H3	L1	L2	
TD65-36/2	200	260	208	128	128	144	105	209	724	400	200	87
TD65-48/2	200	260	208	128	128	144	105	209	724	400	200	94



Shoufei Pump

Model	electric motor(KW)	Q(m ³ /h)	10	20	30	40	50	60	70	80	90
TD65-15/2	2.2	H(m)	17.9	17.0	15.0	10.7					
TD65-19/2	3		21.7	20.8	19.0	15.2					
TD65-22/2	4		25.1	24.7	23.9	22.0	17.5				
TD65-30/2	5.5		32.4	32.1	31.5	30.0	26.1				
TD65-34/2	7.5		38.6	38.2	37.6	36.4	34.0	29.6			
TD65-40/2	11		43.4	42.9	42.3	41.4	40.0	37.6			
TD65-50/2	15		53.6	53.3	52.7	51.6	50.0	47.3			
TD65-61/2	18.5		63.2	63.1	63.0	62.3	61.0	58.8	54.8		
TD65-67/2	22		68.0	67.8	67.7	67.5	67.0	65.8	63.4	59.7	
TD65-83/2	30		85.4	85.1	84.6	83.9	83.0	81.7	80.0	77.8	74.2

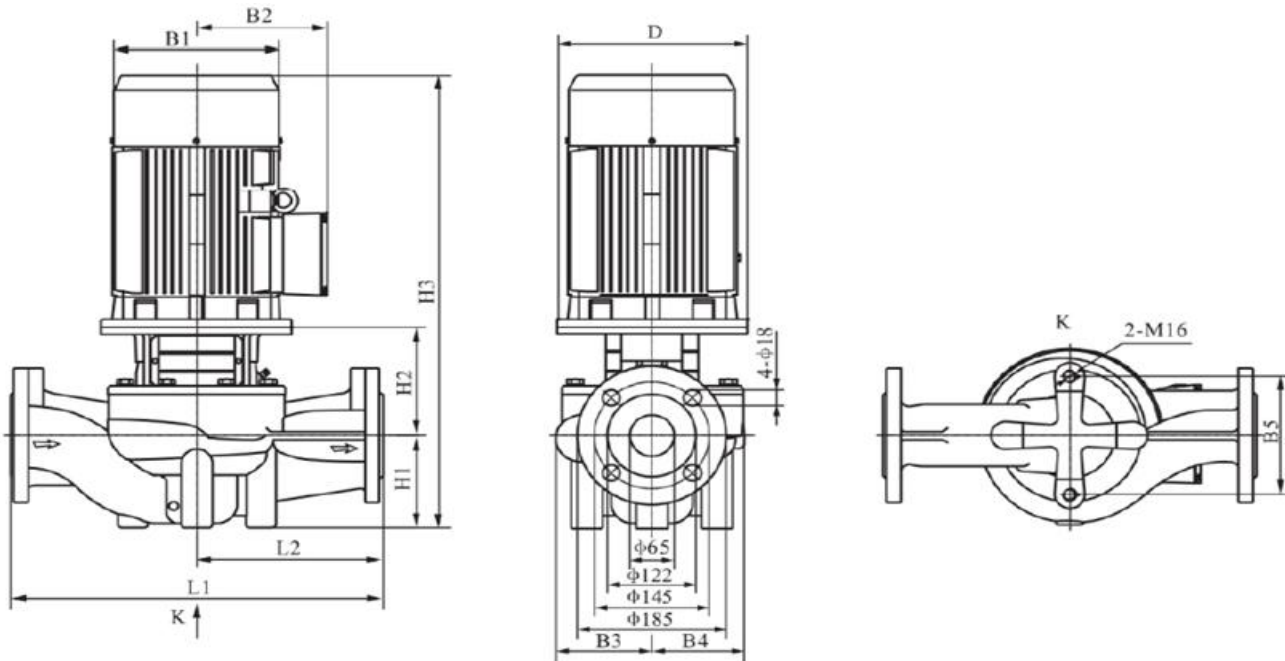

Model	Dimension(mm)											Weight (kg)
	D	B1	B2	B3	B4	B5	H1	H2	H3	L1	L2	
TD65-15/2	140	190	155	142	124	144	105	193	591	360	180	48
TD65-19/2	160	197	165	142	124	144	105	203	622	360	180	57
TD65-22/2	160	230	188	142	124	144	105	203	643	360	180	65
TD65-30/2	200	260	208	142	124	144	105	223	738	360	180	84
TD65-34/2	200	260	208	142	124	144	105	223	738	360	180	91
TD65-40/2	350	330	255	179	167	144	125	257	924	475	238	178
TD65-50/2	350	330	255	179	167	144	125	257	957	475	238	190
TD65-61/2	350	330	255	179	167	144	125	257	957	475	238	202
TD65-67/2	350	330	255	179	167	144	125	257	987	475	238	242
TD65-83/2	350	330	255	179	167	144	125	257	1047	475	238	298



Shoufei Pump

Model	electric motor(KW)	Q(m ³ /h)	10	20	30.0	40	50.0	60	65.0
TD80-40/2	11	H(m)	42.8	42.8	42.7	41.8	40.0	36.5	
TD80-48/2	15		50.4	50.4	50.2	49.5	48.0	45.0	42.6

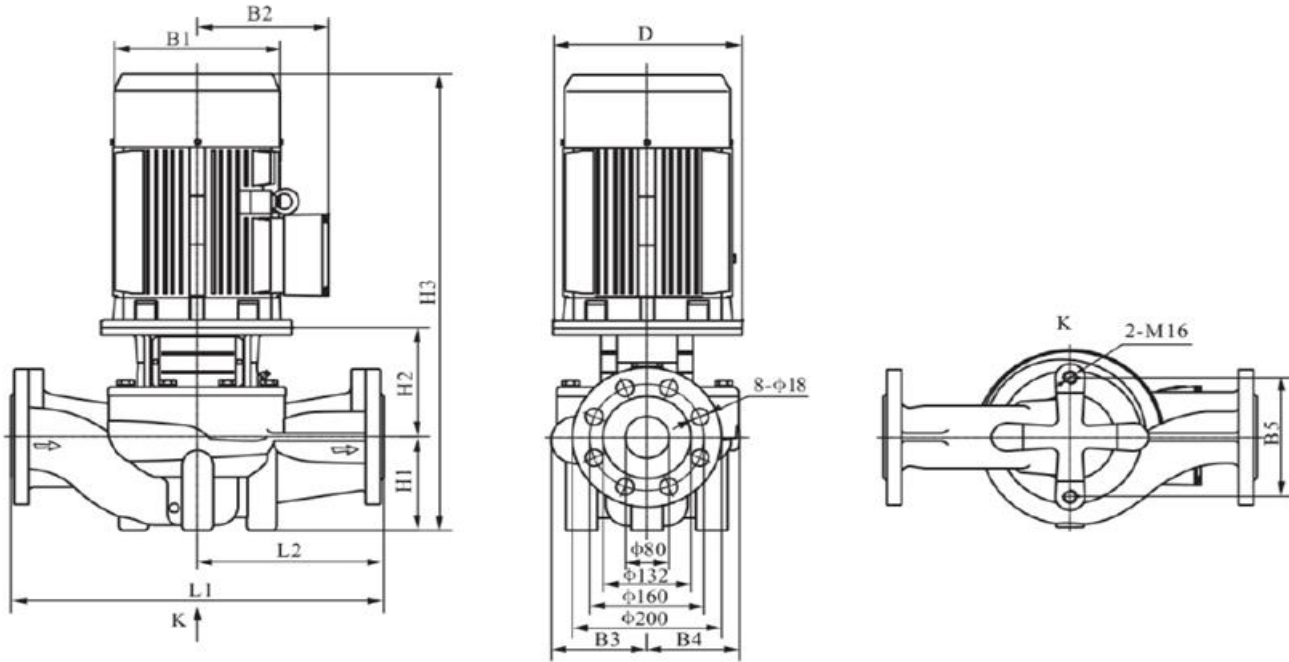

Model	Dimension(mm)											Weight (kg)
	D	B1	B2	B3	B4	B5	H1	H2	H3	L1	L2	
TD80-40/2	350	330	255	137	128	144	115	235	892	500	250	172
TD80-48/2	350	330	255	137	128	144	115	235	925	500	250	183



Shoufei Pump

Model	electric motor(KW)	Q(m ³ /h)	10	20	30	40	50	60	70	80	90	100
TD80-13/2	3	H(m)	16.1	15.8	15.2	14.3	13.0	10.9				
TD80-18/2	4		21.1	20.8	20.2	19.2	18.0	16.2	13.2			
TD80-22/2	5.5		24.4	24.1	23.7	23.0	22.0	20.5	18.0	14.3		
TD80-28/2	7.5		30.6	30.4	30.0	29.3	28.0	26.3	24.0	20.6		
TD80-30/2	11		34.8	34.5	34.2	33.8	33.2	32.4	31.3	30.0	27.8	24.7
TD80-38/2	15		41.2	41.2	41.1	40.9	40.6	40.1	39.3	38.0	36.0	32.9
TD80-47/2	18.5		50.6	50.4	50.0	49.8	49.6	49.1	48.3	47.0	44.8	41.4
TD80-54/2	22		57.0	57.0	56.8	56.6	56.3	56.0	55.3	54.0	52.2	49.2
TD80-67/2	30		69.2	69.0	68.8	68.7	68.6	68.3	67.8	67.0	65.9	63.9

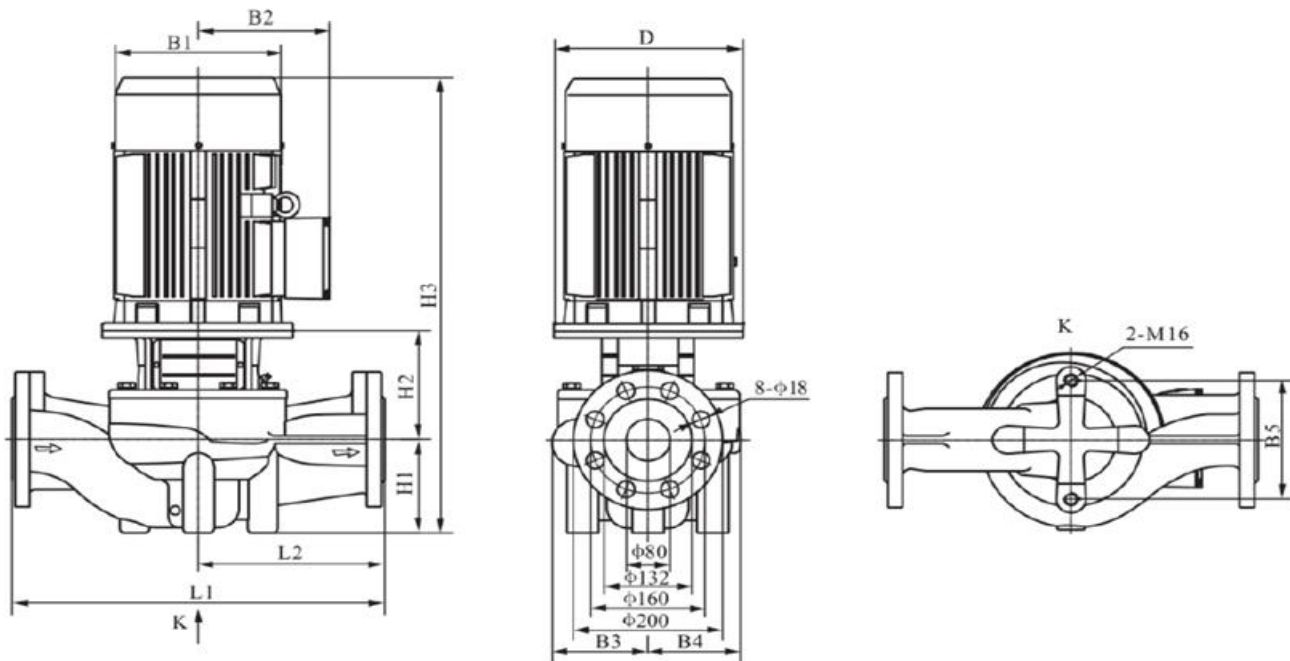

Model	Dimension(mm)											Weight (kg)
	D	B1	B2	B3	B4	B5	H1	H2	H3	L1	L2	
TD80-13/2	160	197	165	142	124	160	97	243	654	450	225	64
TD80-18/2	160	230	188	142	124	160	97	243	675	450	225	72
TD80-22/2	200	260	208	142	124	160	97	263	770	450	225	90
TD80-28/2	200	260	208	142	124	160	97	263	770	450	225	100
TD80-30/2	350	330	255	182	163	144	115	274	931	500	250	184
TD80-38/2	350	330	255	182	163	144	115	274	964	500	250	192
TD80-47/2	350	330	255	182	163	144	115	274	964	500	250	208
TD80-54/2	350	330	280	182	163	144	115	274	994	500	250	244
TD80-67/2	400	400	305	182	163	144	115	274	1054	500	250	302